





ASSEMBLY INSTRUCTIONS (INSTRUCTIONS D'ASSEMBLAGE)

HARDWARE LIST (LISTE DES OUTILS):

NO. NO.	Sketch Schéma	Description Description	Qty Qté
1		Bolt(1/4" x 3/4") Boulon	12 PCS 12 PCES
2		Spring Washer(1/4") Rondelle frein	12 PCS 12 PCES
3		Washer(1/4") Rondelle plate	12 PCS 12 PCES
4		Allen Wrench(4mm) Clé hexagonale	1 PC 1 PCE

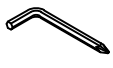
PARTS LIST (LISTE DES PIECES):

NO. NO.	Sketch Schéma	Description Description	Qty Qté
A		Cabinet Armoire	1 PC 1 PCE
B		Leg Pied	4 PCS 4 PCES

Step 1 / Étape 1

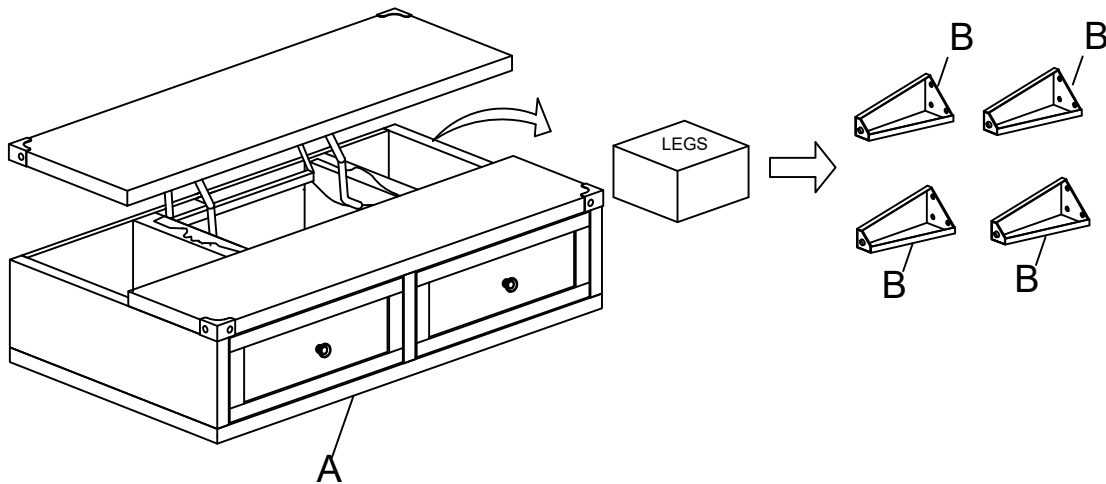

Step 2 / Étape 2

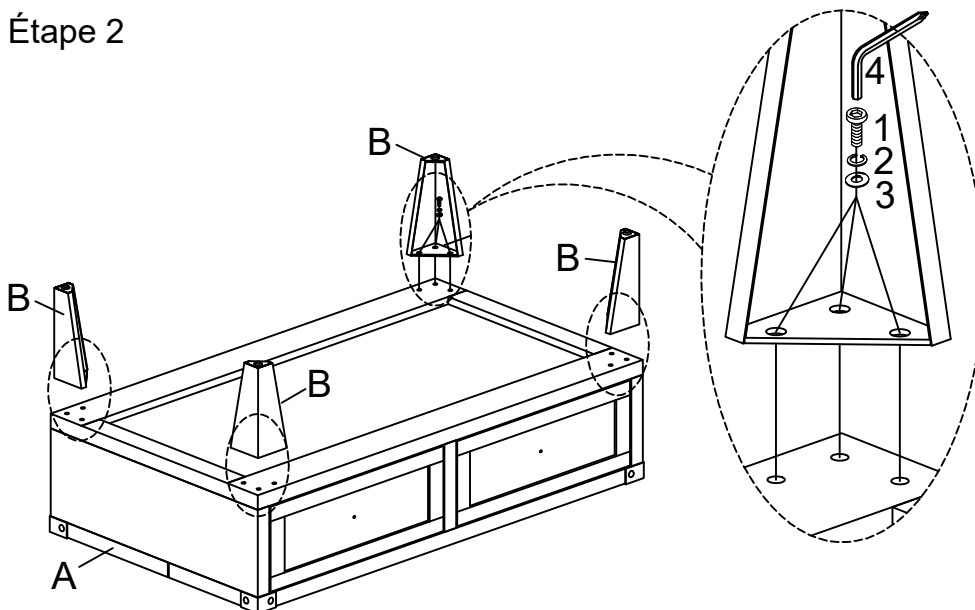

ASSEMBLY INSTRUCTIONS (INSTRUCTIONS D'ASSEMBLAGE)

Step 3 / Étape 3

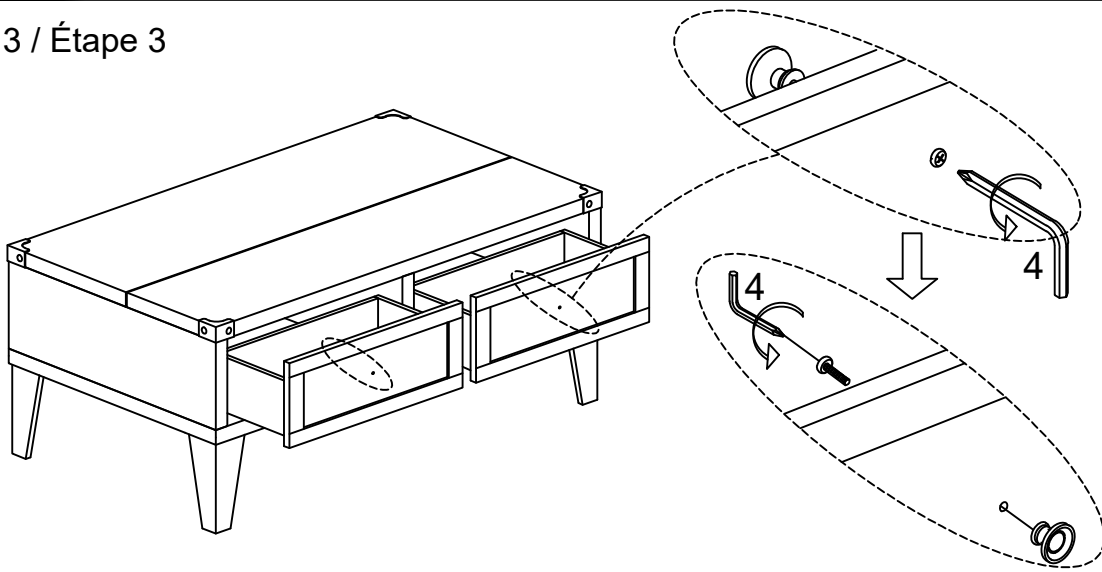

Step 4 / Étape 4

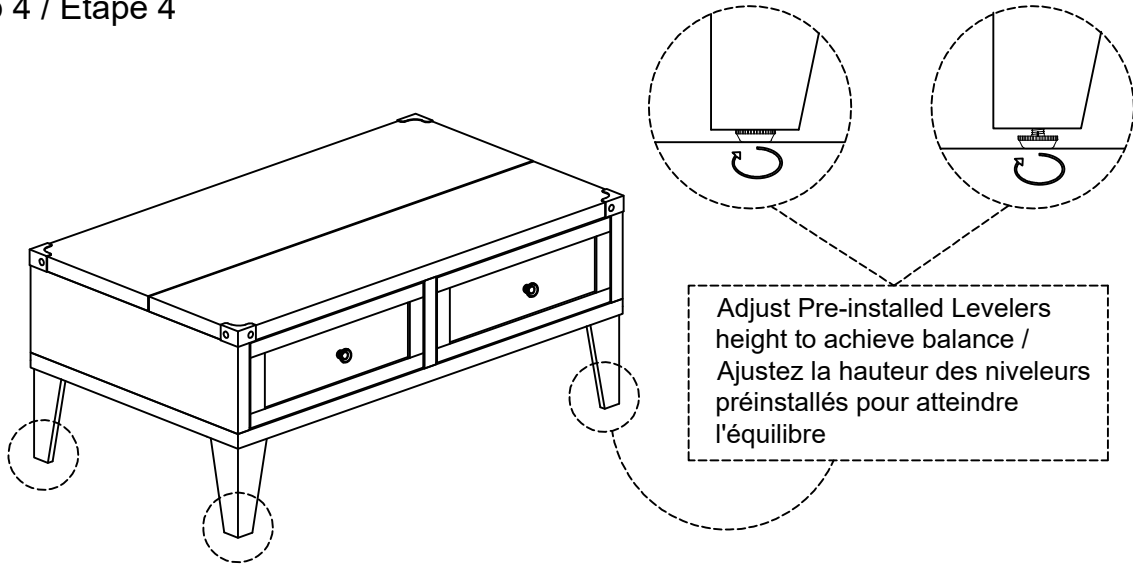

Step 5 / Étape 5

